

## Design and Analysis of a Novel OTA-C Voltage-Mode to Current-Mode Biquad Filter

Michael O'Connor<sup>\*1</sup>, John F. Doyle<sup>\*2</sup> and Patrick D. Hughes<sup>\*3</sup>

<sup>\*1</sup>Department of Engineering, University College Dublin, Ireland

<sup>\*2</sup>School of Physics, University of Glasgow, UK

<sup>\*3</sup>Department of Applied Mathematics, University of Edinburgh, UK

---

### ABSTRACT

This paper introduces three new OTA-C universal biquad filters which offers almost all of the desirable features (as expected in a good biquad) simultaneously with any major tradeoffs. The two biquads (a VM-based biquad and a CM-based biquad) are combined efficiently to form a hybrid biquad that can be digitally controlled to convert into either of the two with similar responses. The workability of the new circuits has been well established by SPICE simulation results of their CMOS-implementable versions.

**KEYWORDS:** Biquad Filters, Tunable Filters, Voltage Mode Biquads, Current Mode Biquads, Operational, transconductance amplifier.

---

### I. INTRODUCTION

Filters are one of the most important circuits in the field of instrumentation, communication, control, neural network etc. As filter's function is to capture required frequency and curtail undesired one, it is an integral part of a signal processing circuit. With the advancement of integrated circuit (IC) design technology, there is need to shrink the circuit size along with programmable compatibility to make it more compact, more user friendly and suitable for IC design. Universal filter is a filter which can be used to implement a various filter functions depending on user needs from the same topology. In last few decades, operational transconductance amplifiers (OTAs) perform very well in circuit design due to its various advantages i.e. electronic tunability of transconductance gain, larger bandwidth, high slew rate, low power consumption etc. Moreover, OTA does not need any resistance, as a result, it is suitable for integrated circuit implementation. OTA-C structures are highly suitable for realizing electronically tunable continuous time filters in a variety of technologies such as bipolar, CMOS and BiCMOS, and therefore have been widely investigated for designing voltage-mode (VM) as well as current-mode (CM) filters [10]. Although a number of VM and CM OTA-C biquads have been reported in earlier literature referenced above but none has reported a hybrid OTA-C filter

A good MOTA type CM /VM biquad filter should simultaneously exhibit the following desirable features, without trade-offs [1]:

- (i) Realisability of all the standard filter functions namely, low pass (LP), band pass (BP), high pass (HP), notch and all pass (AP)
- (ii) Realisability of all the five functions without requiring any design constraint/matching conditions

Independent tunability of  $\omega_0$  and  $Q_0$

### II. THE PROPOSED STRUCTURE

1. **Universal VM biquad realization:** The proposed structure is shown in fig.1. A straight forward analysis reveals the following transfer functions for the configuration in fig 1.

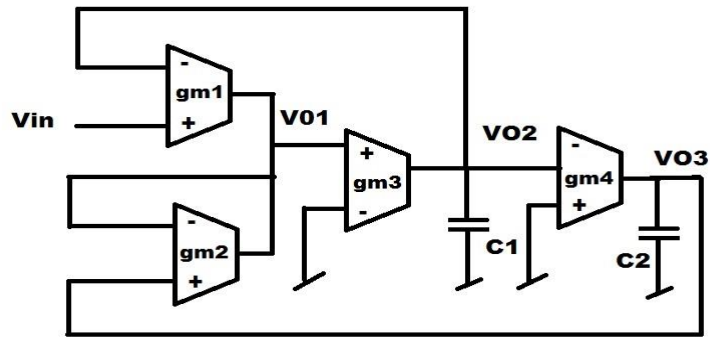

Figure 1: OTA Voltage Mode Biquad Filter obtained from 4 OTAs and two capacitors.

$$\frac{V01}{V_{in}} = \left(\frac{gm1}{gm2}\right) \frac{S^2}{D(s)} = \frac{H_0 S^2}{D(s)} \quad (1)$$

$$\frac{V02}{V_{in}} = \left(\frac{gm1}{gm2}\right) \frac{\left(\frac{gm3}{C1}\right) S}{D(s)} = \frac{H_1 S}{D(s)} \quad (2)$$

$$\frac{V03}{V_{in}} = -\left(\frac{gm1}{gm2}\right) \frac{\left(\frac{gm3 gm4}{C1 C2}\right)}{D(s)} = \frac{H_3}{D(s)} \quad (3)$$

Where

$$D(s) = S^2 + \left(\frac{gm1}{gm2}\right) \left(\frac{gm3}{C1}\right) S + \frac{gm3 gm4}{C1 C2} \quad (4)$$

2. **Universal CM biquad realization:** The proposed structure is shown in fig.2. A straight forward analysis reveals the following transfer functions for the configuration in fig

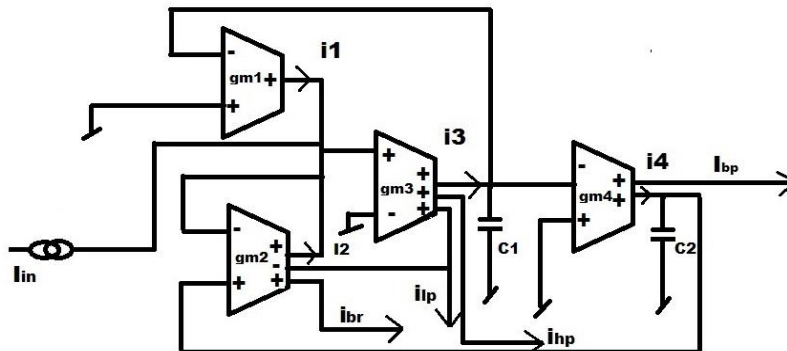

Figure 2: OTA Current Mode Biquad Filter 4 OTAs and 2 capacitors.

$$\frac{I_{hp}}{I_{in}} = \frac{I_3}{I_{in}} = \left(\frac{gm3}{gm1}\right) \frac{S^2}{D(s)} = \frac{H_0 S^2}{D(s)} \quad (5)$$

$$\frac{I_1}{I_{in}} = \left(\frac{gm1}{gm2}\right) \frac{\left(\frac{gm3}{C1}\right) S}{D(s)} = \frac{H_1 S}{D(s)} \quad (6)$$

$$\frac{I_{lp}}{I_{in}} = \frac{\left(\frac{gm3 gm4}{C1 C2}\right)}{D(s)} = \frac{H_3}{D(s)} \quad (7)$$

$$\frac{I_{br}}{I_{in}} = \frac{I_2}{I_{in}} = \frac{\left( S^2 + \frac{gm_3 gm_4}{C_1 C_2} \right)}{D(s)} = \frac{H_3}{D(s)} \quad (8)$$

Where

$$D(s) = S^2 + \left( \frac{gm_1}{gm_2} \right) \left( \frac{gm_3}{C_1} \right) S + \frac{gm_3 gm_4}{C_1 C_2} \quad (9)$$

It is easy to verify that all pass filter can be achieved in the CM-based biquad filter by a connecting the appropriate terminals without requiring any design constraints or matching conditions. Furthermore in both the case, various filter parameters can be electronically tuned by varying the transconductances of the various OTAs as follows. IN the circuit of fig W<sub>0</sub> can be varied by varying gm<sub>3</sub> while keeping all others constant and Q<sub>0</sub> can be varied by varying gm<sub>2</sub> while keeping all others constant.

$$W_0 = \sqrt{\frac{gm_3 gm_4}{C_1 C_2}} \quad (10)$$

$$Q_0 = \frac{gm_2}{gm_1} \sqrt{\frac{gm_4 C_1}{gm_3 C_2}} \quad (11)$$

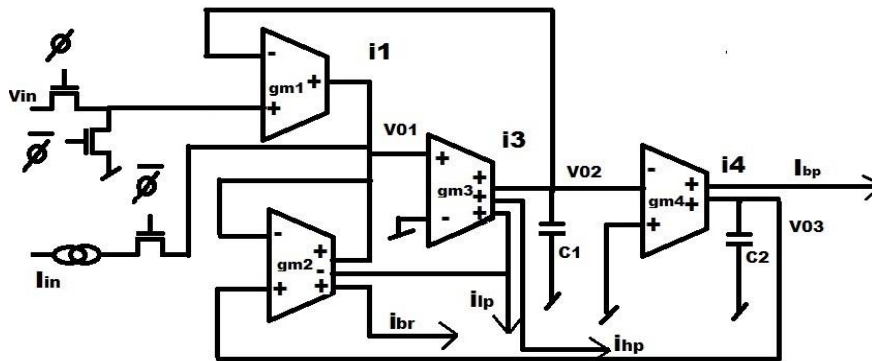

Figure 3. Hybrid biquad filter with both V-mode and C-mode operation is obtained from 4 OTAs and 2 capacitors.

### III. CMOS IMPLEMENTATION AND SPICE RESULTS

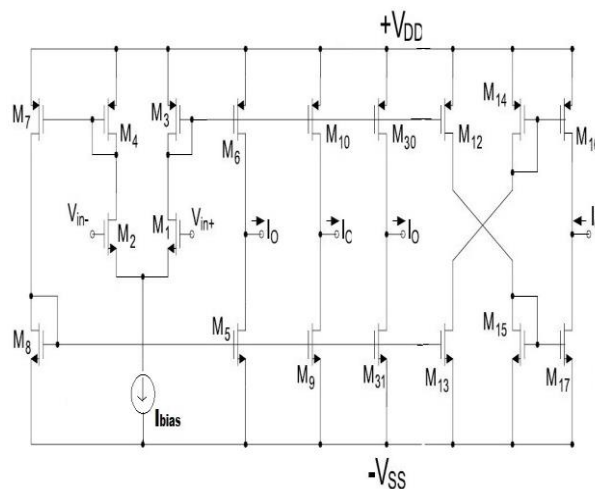

Figure 4: CMOS OTA circuit for the design of Biquad filters [7].

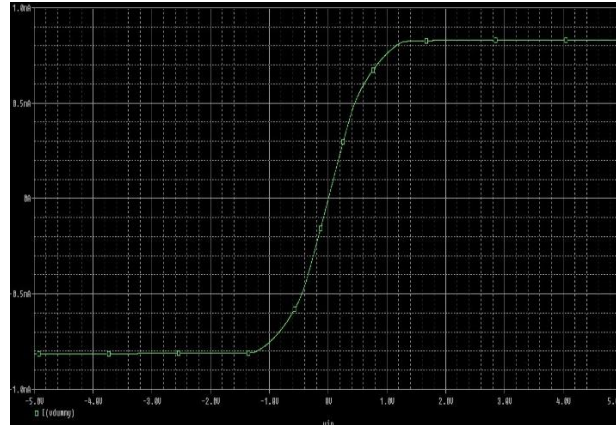

Figure 5: *Gm* graph of CMOS OTA given in SPICE [7].

The circuits were designed using 0.5um MIETEC CMOS process technology in spice. The CMOS multiple input OTA(MOTA) structure shown in fig. 2 which was biased with  $\pm 2.5v$  DC power supply, with bias currents for four OTA's taken as  $I_{bias1} = I_{bias2} = I_{bias3} = I_{bias4} = 25uA$ . The aspect ratios(W/L) for the MOSFETs were taken as:

Table 1: Transistor sizing

Transistors	W/L Ratio
M1,M2	10/1
M3,M4,M5,M8,M13,M15,M17,M31	15/1
M6,M7,M10,M12,M14,M16,M30	8/1

All the filter circuits employed  $C_1 = 10pF$  and  $C_2 = 20pF$  resulting in identical filter parameters as:

$f_o = 1.8 \text{ MHz}$  ,  $Q_o = 0.598$ ,  $G_m = 480uS$

**VM-biquad:** TOTAL POWER DISSIPATION 1.89E-03 W

**CM-biquad:** POWER DISSIPATION 3.47E-03 W

**Hybrid Biquad:** POWER DISSIPATION 8.14E-03 W.

With  $gm1 = gm2$  and  $gm3 = gm4$ ,  $Q_o$  can be fixed at 0.5 while we can vary  $f_o$  by varying  $gm3$ . This could offer a ease of tunability with just one transconductance variation.

Fig1, 2 shows the frequency response of VM-based biquads and CM-based biquads. The modified circuits for both the modes is shown in fig 3. The frequency response is same as the individual frequency responses of VM and CM-mode biquads as shown in fig 6,7. The circuit acts as CM-based biquad when  $\phi = 0$  and as VM-based biquad when  $\phi = 1$ . The tunability properties of all the three circuits have also been confirmed by SPICE simulation by changing the various transconductances through respective DC bias currents. The SPICE simulation results have been found to exhibit very close correspondence with the theoretical values which establish the workability of the new circuits.

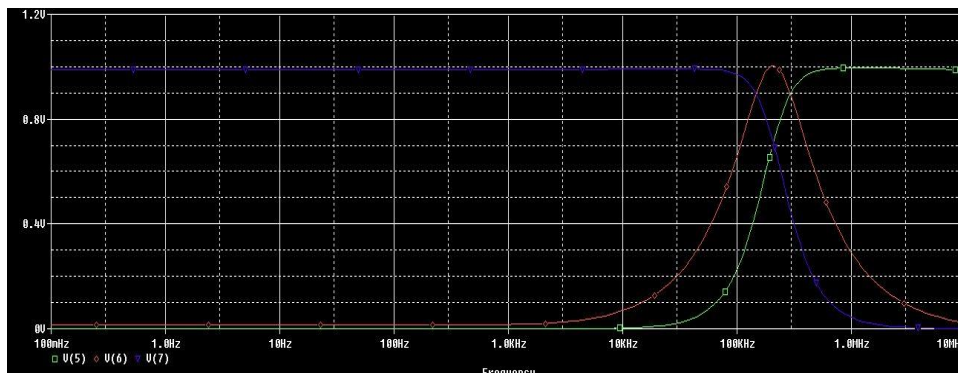

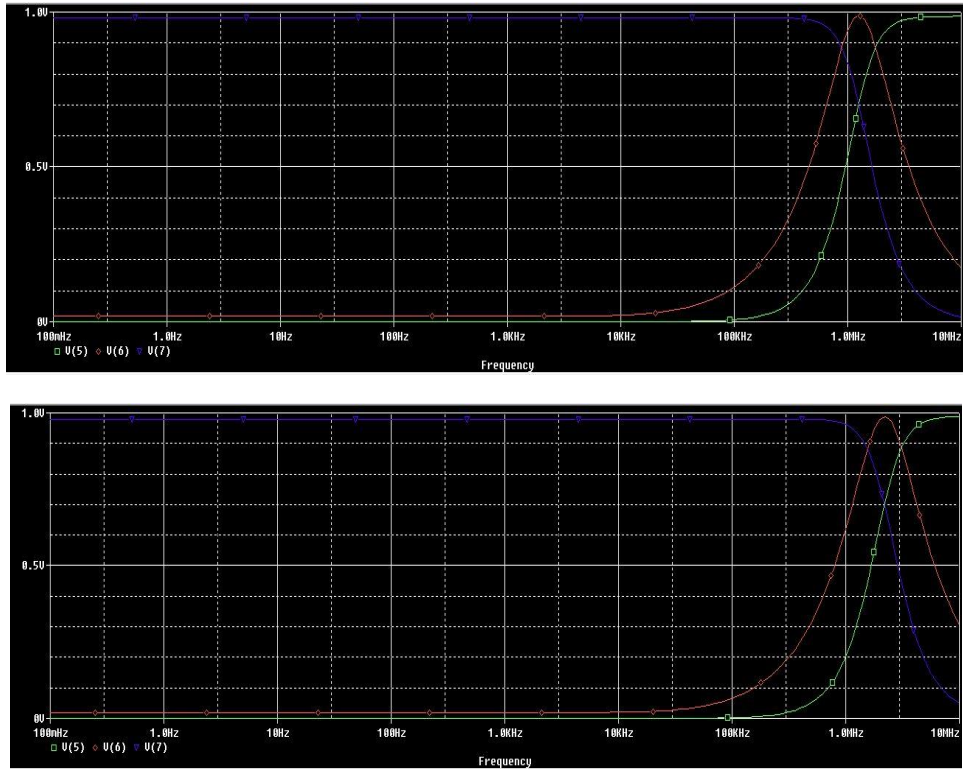
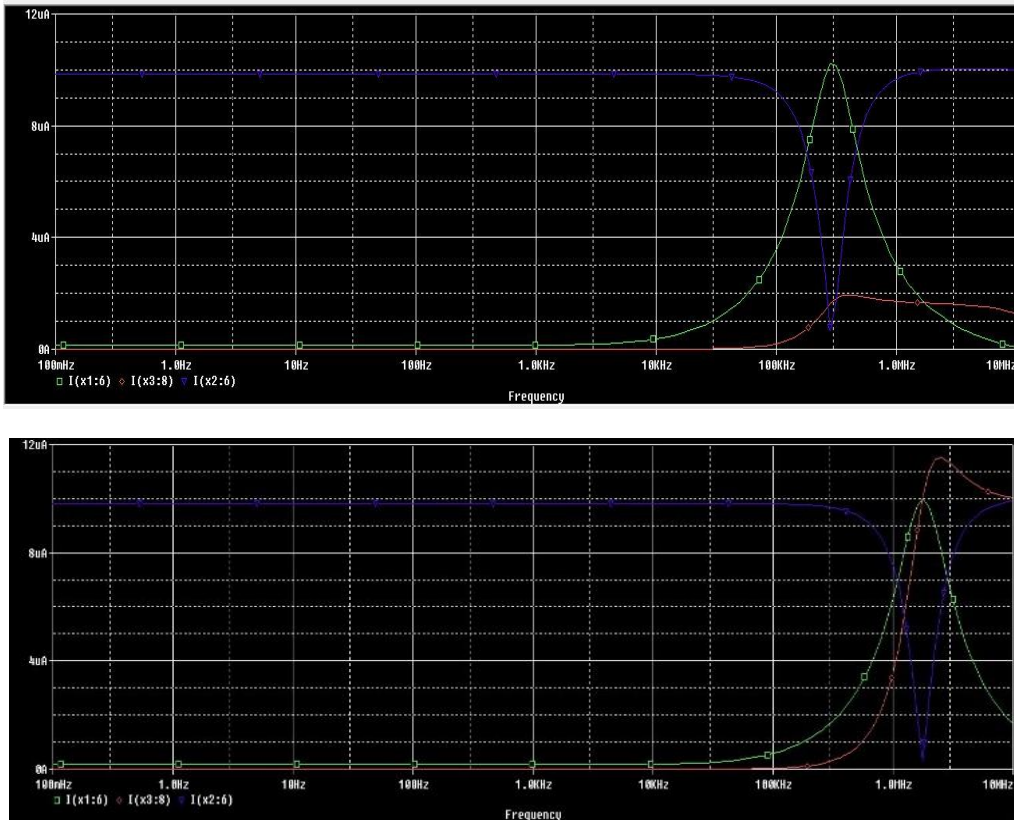

Figure 6: VM-biquad Filter responses for various Ibiases. (10ua, 20ua, 50ua)



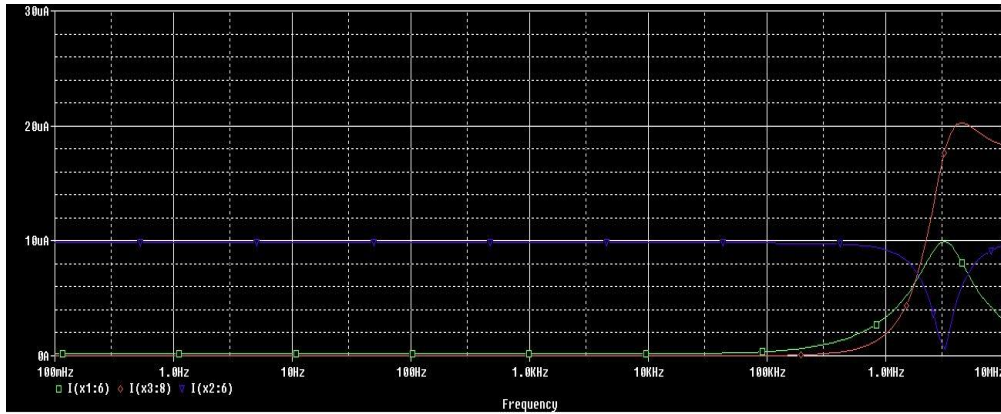

Fig 7: CM-biquad Filter responses for various Ibiases (15ua, 50ua, 100ua)

#### IV. CONCLUSION

A CMOS OTA based programmable and electronically tunable MOTA resistor less analog universal filter has been proposed theoretically and verified by PSPICE simulation using CMOS 0.5  $\mu\text{m}$  technology. All simulation results shown here agreed well with the theoretical expectation. The proposed universal filter is well suited for IC fabrication, because of having only two grounded passive components and no resistor. The three new OTA-C universal Current mode, Voltage mode and hybrid mode biquads have been introduced which offer all the desirable features highlighted without any tradeoffs. With applying a logic 1 or 0 at the gates of the control transistors added in the third circuit, we can easily switch between the two modes. This offers a high portability to the user in a single circuit with many functions. The workability of all the proposed structures has been established SPICE simulation results of their CMOS implementable versions. Because of their advantageous features, the proposed circuits appear to be eminently suitable for integrated circuit implementation in bipolar, CMOS and BiCMOS technologies.

#### V. REFERENCES

- [1] Ugur Cini, Mustafa Aktan.: Dual-mode OTA based biquadratic filter suitable for current-mode applications. Int. J. Electron. Commun. (AEÜ) .Vol. 80, 43-47, 2017.
- [2] Dries Peumans, G. Vandersteen.: An Improved Describing Function with Applications for OTA-Based Circuits. Circuits and Systems I: Regular Papers.IEEE Transactions, 2017.
- [3] Jirayuth Mahattanakul and Chris: Current-Mode Vs Voltage-Mode - Biquad Filters: What the Theory Says. IEEE Transactions on Circuits and Systems-II: Analog and Digital Processing. VOL. 4, 1998.
- [4] E. Sanchez-Sinencio and J. Silva-Martinez, "CMOS transconductance amplifiers, architectures and active filters: a tutorial." IEEE proceedings circuits, devices and systems, vol. 147. 3—2 ( 2000)
- [5] Soliman. A. Mahmoud and I.A. Awad.: New CMOS balanced output transconductor and application to Gm-C biquad filter. ISCAS '03. Proceedings of the 2003 International Symposium on Circuits and Systems. Vol 1( 2003)
- [6] Chun-Ming Chang, Bashir M., Al- Hashmi and J. Neil Ross.: Unified active filter biquad structures. IEEE proc.Circuits Devices syst. Vol 51,273-277, 2004.
- [7] Chang.C.M: Analytical Synthesis of the digitally programmable voltage mode OTA-C universal biquad. IEEE Transactions on circuits and Systems-II, Vol 53,607-611,2006
- [8] Bhaskar, D.R., Singh, A.K., Sharma, R.K. and Senani R.: New OTA-C Universal Current-Mode/Trans-Admittance Biquads. IEICE Electronics Express (Japan), Vol. 2 , 8-13 ,2015.
- [9] Jaikla, W. and Siripruchyayum, M.: Electronically Controllable Dual-Mode Universal Bi-Quadratic Filter Using Triple-Output OTAs. The 1st Conference on Sciences and Social Sciences, 864-872, 2008.
- [10] Chen, H., Liao, Y. and Lee, W.: Tunable Mixed-Mode OTA-C Universal Filter. Analog Integrated Circuits and Signal Processing. Vol 58, 135-141, 2009.
- [11] Kamat, D., Anand Mohan, P.V. and Prabhu, K.: Novel First-Order and Second-Order Current-Mode Filters Using Multiple-Output Operational Transconductance Amplifiers. Circuits, Systems and Signal Processing. Vol 29,553-576, 2010.
- [12] Kumngern. M, Knobnob. B and Dejhan. K.: Electronically tunable high input impedance voltage-mode universal biquadratic filter based on simple CMOS OTAs. Int. J. Electron. Commun. (AEÜ) Vol. 64,934-939, 2010.
- [13] Lee, C.: Multiple-Mode OTA-C Universal Biquad Filters. Circuits, Systems and Signal, 2010.
- [14] Montree Kumngern: Versatile MIMO Voltage-Mode OTA-C Universal Biquadratic Filter. IEEE International Symposium on Integrated Circuits, 2011.

- [15] Nishtha rani, Rajeev Kumar Ranjan, Ratnadeep Pal, Sajal K. Paul.: Programmable and electronically tunable voltage-mode universal biquad filter based on simple OTA. Third International Conference on Devices, Circuits and Systems (ICDCS'16) ,2016.
- [16] Manish Gupta: New single input multiple output current mode biquad filter using OTAs Current Mode Biquad Filter Using OTAs. Circuits and Systems, Vol. 7. 231- 238, 2016.